

1.

M1 380\_08

rauch

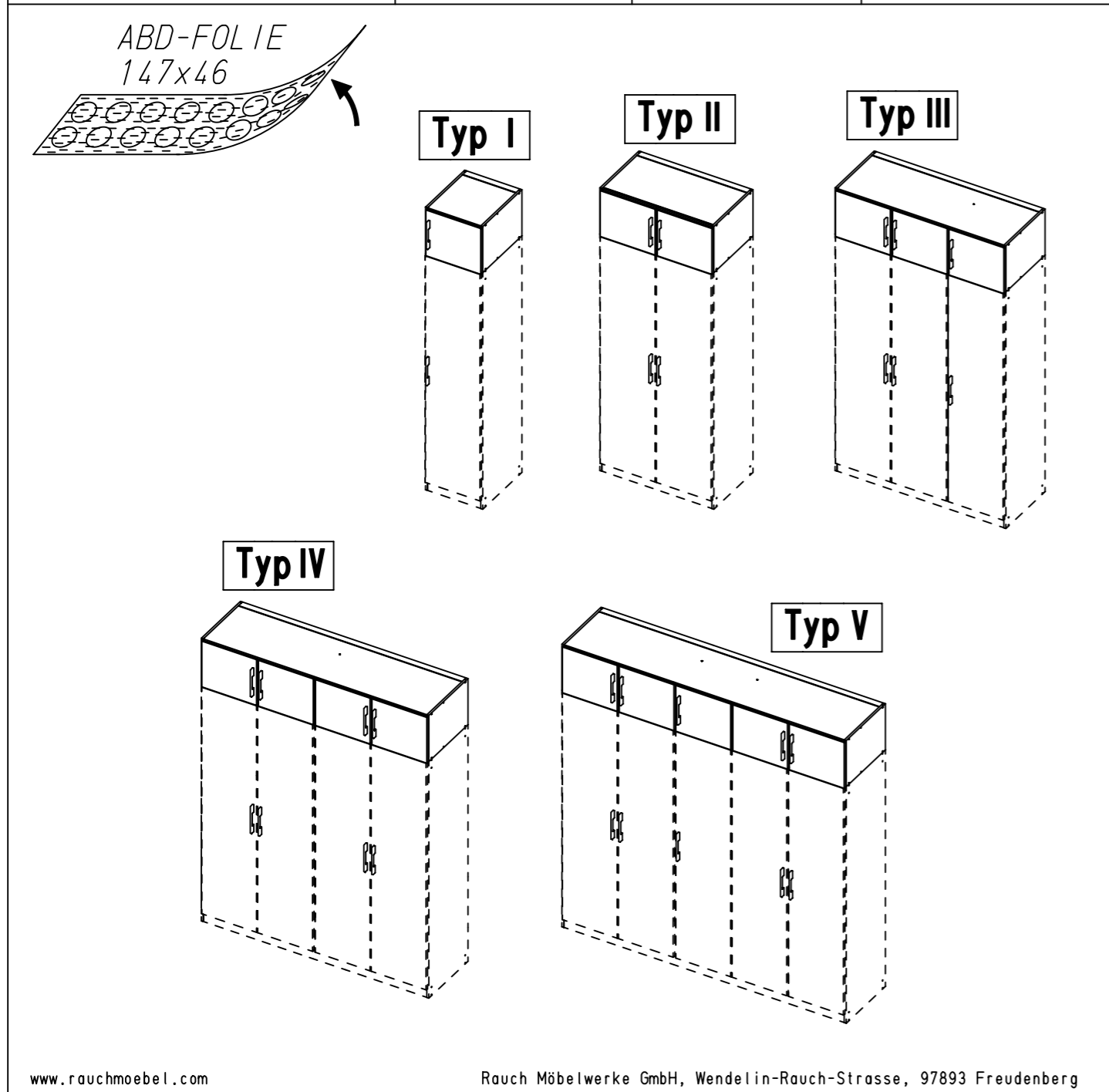
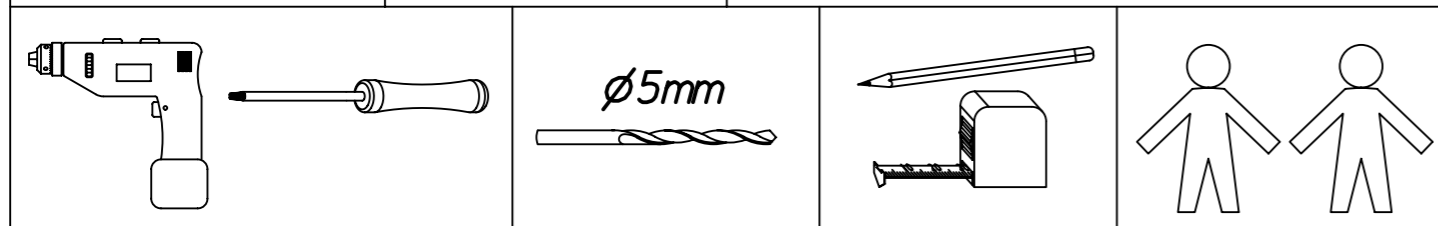
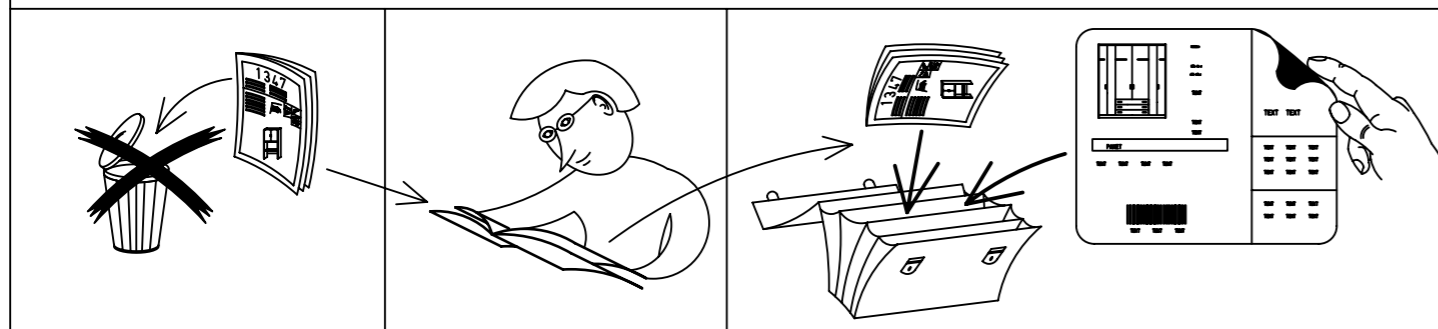

2.

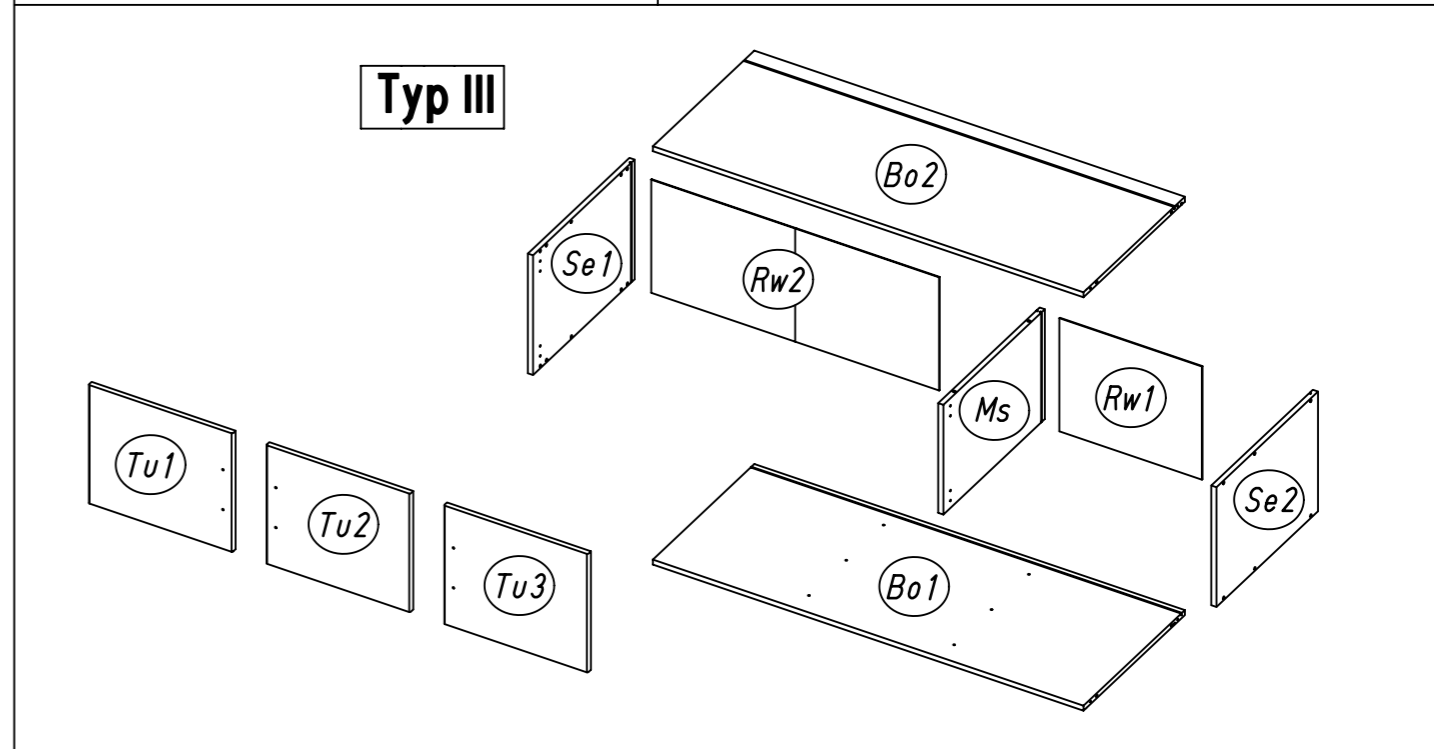
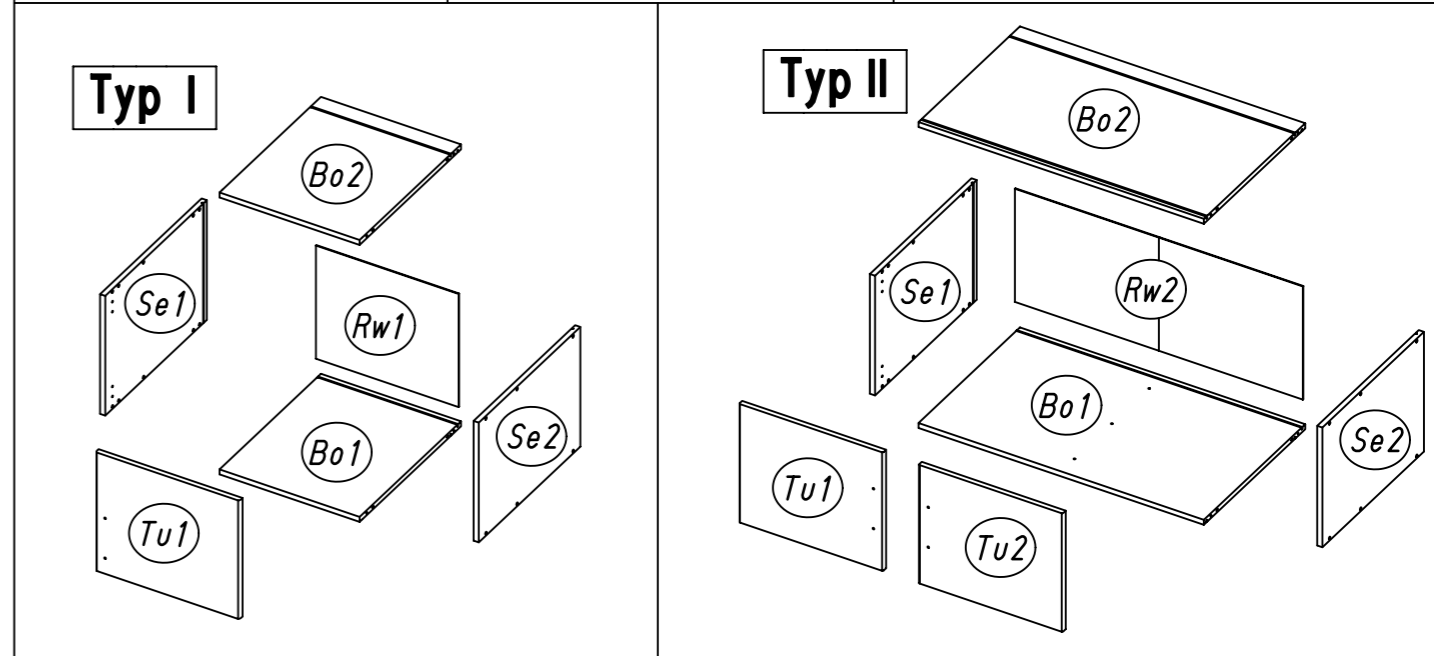
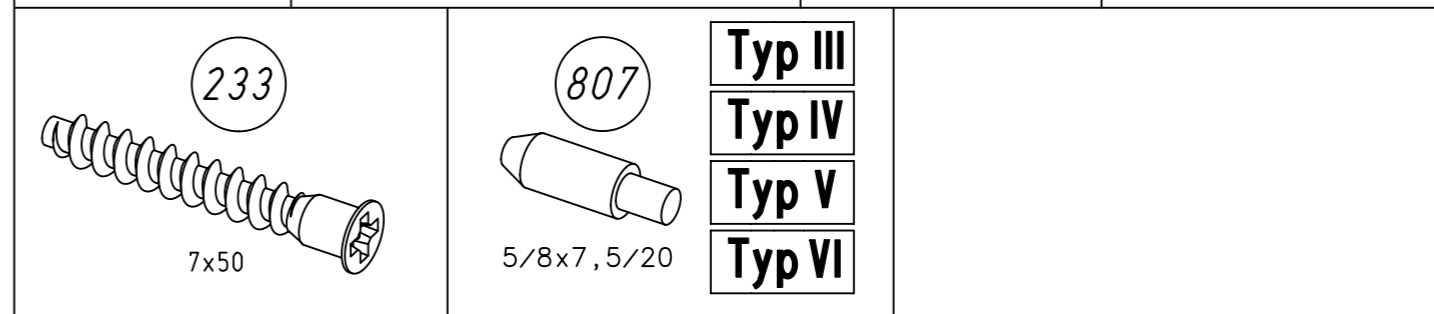
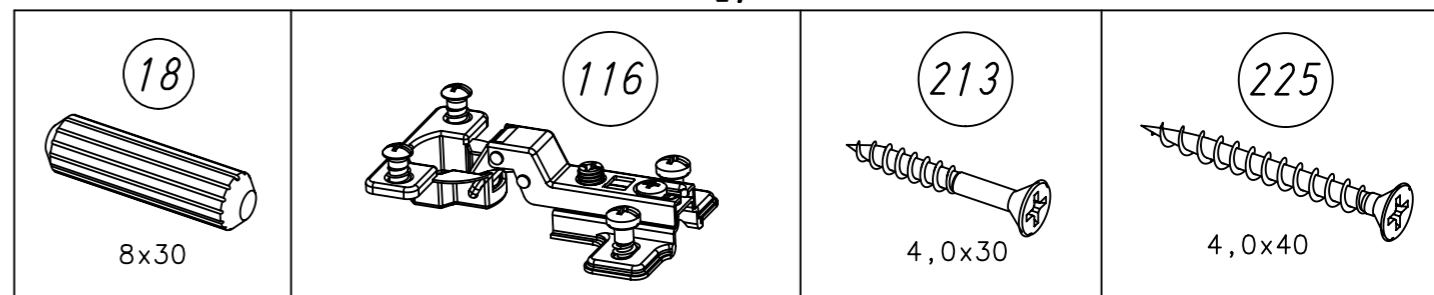

Typ IV

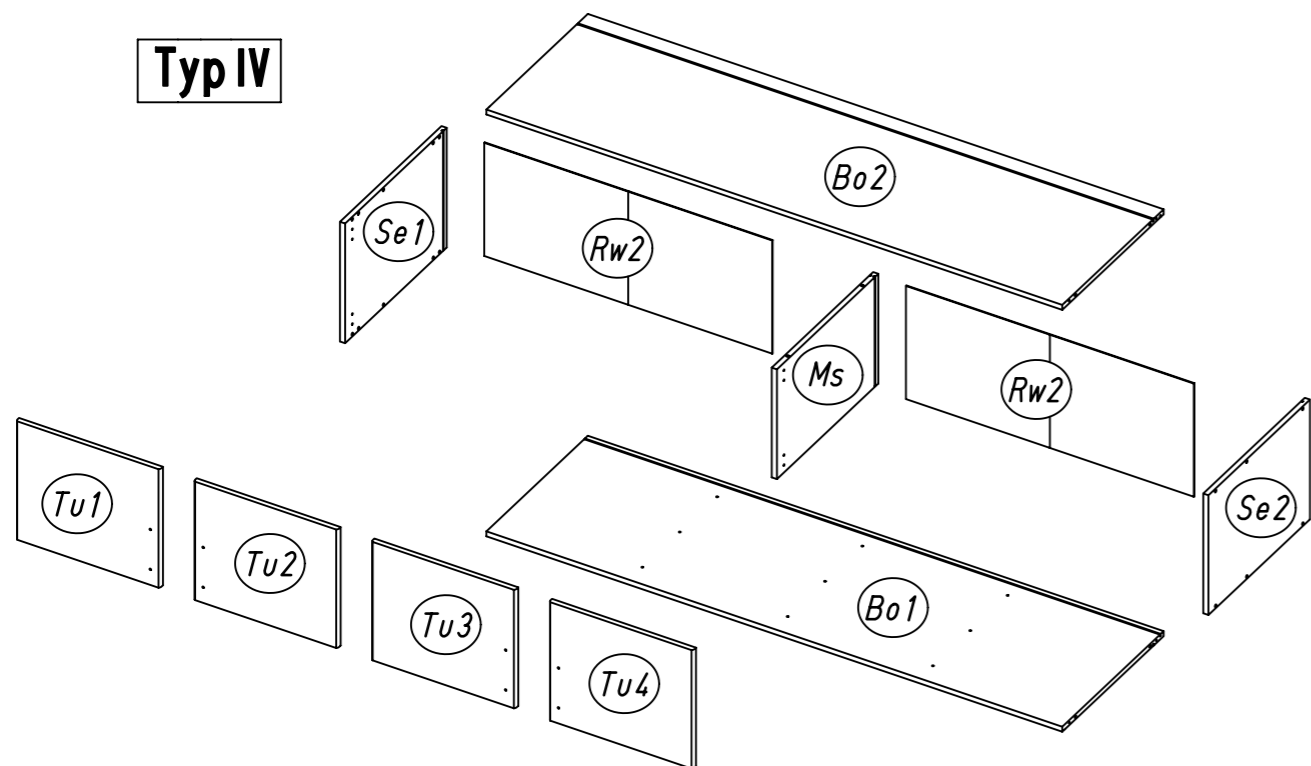

Typ V

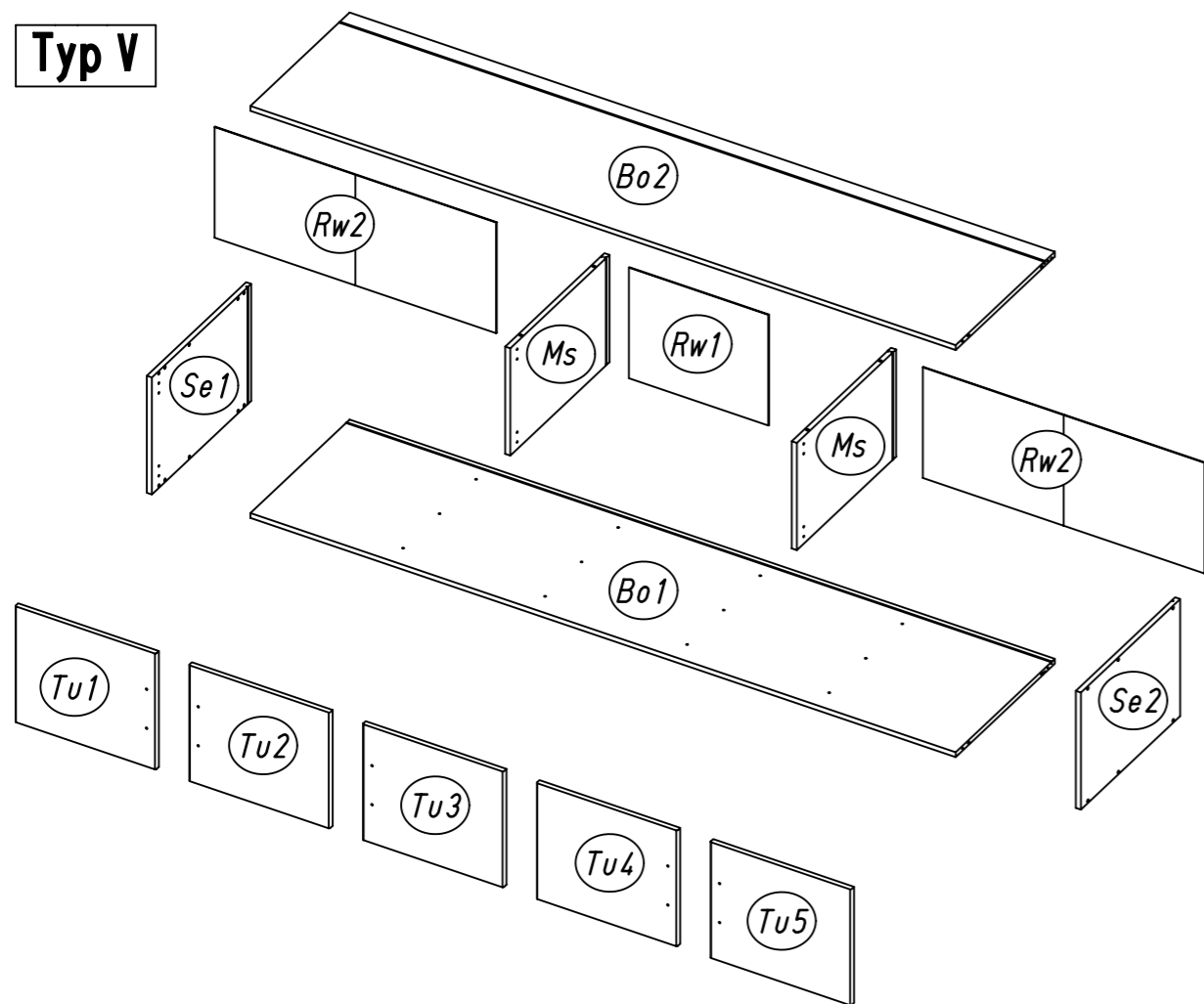

1

Typ III

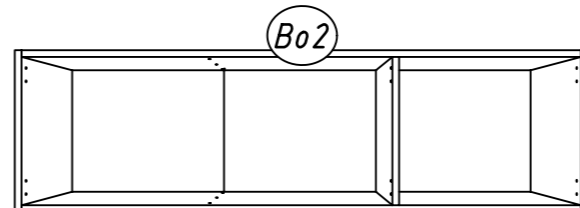

Typ IV

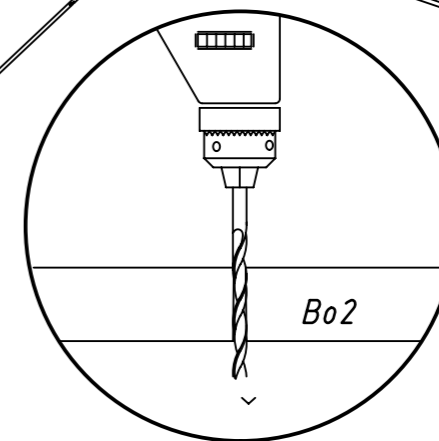
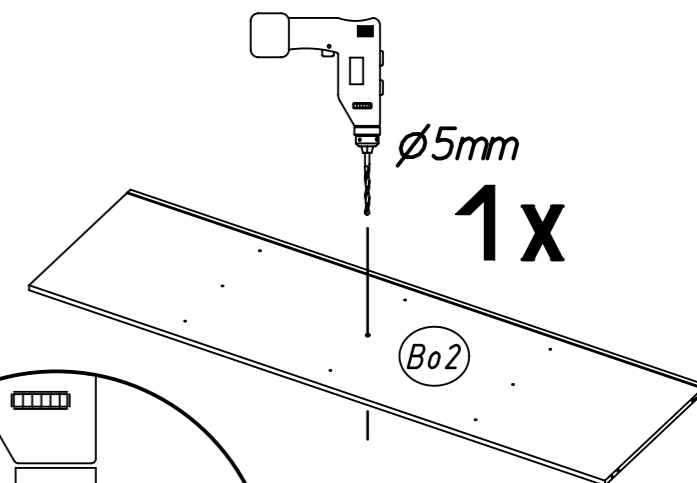
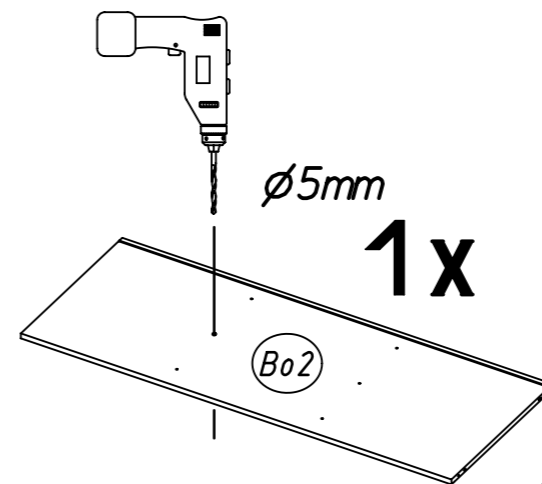
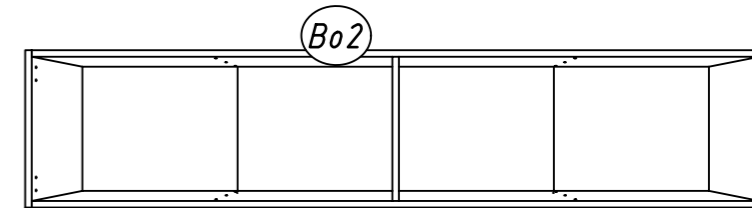

Typ V

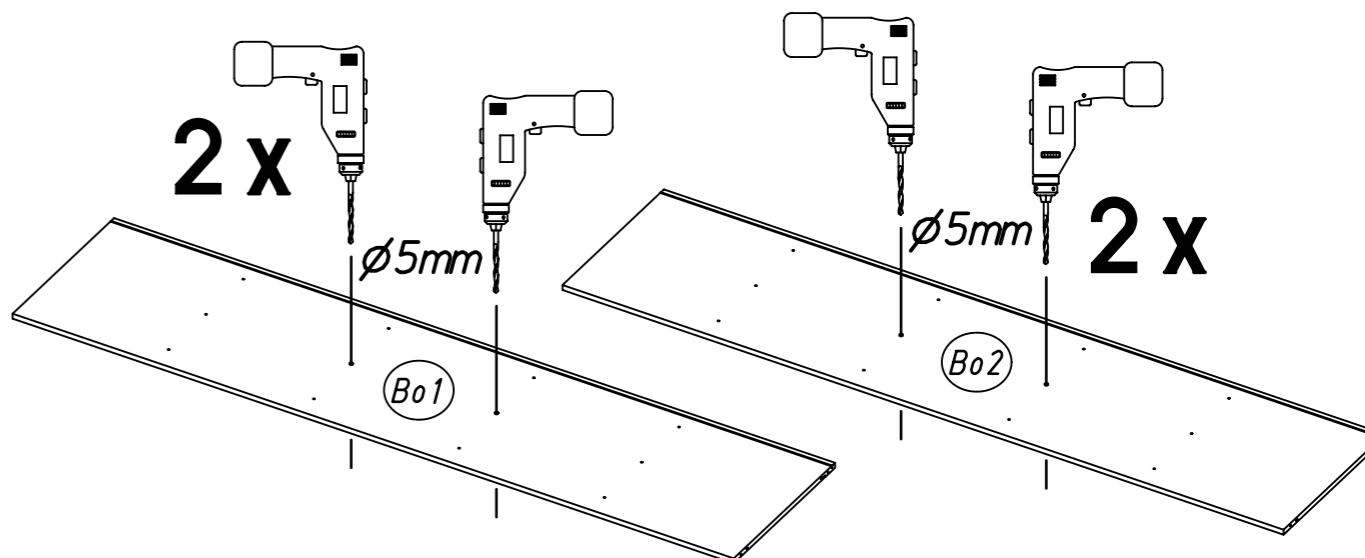
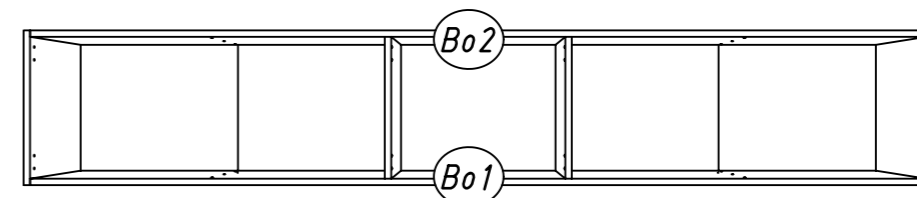

2 18 Typ I Typ II Typ III Typ IV Typ V

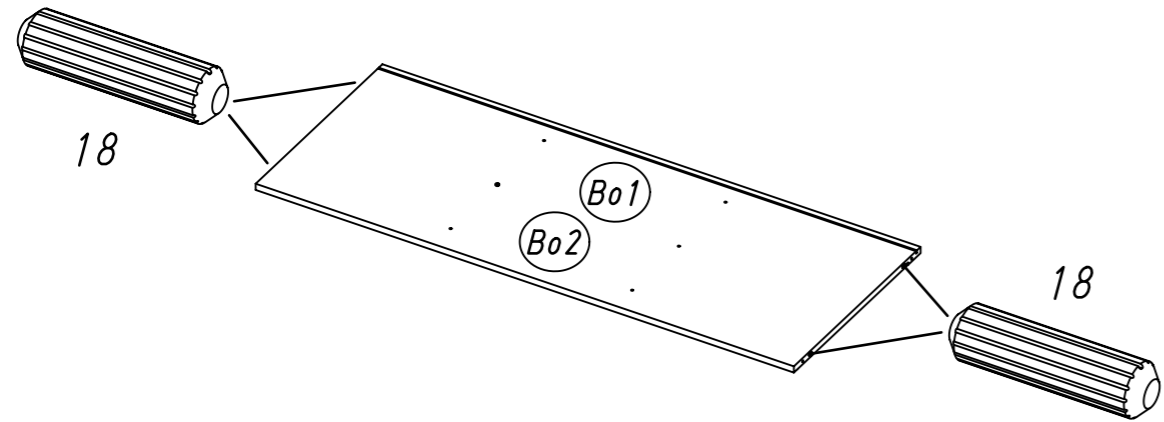

3 233 Typ I Typ II Typ III Typ IV Typ V

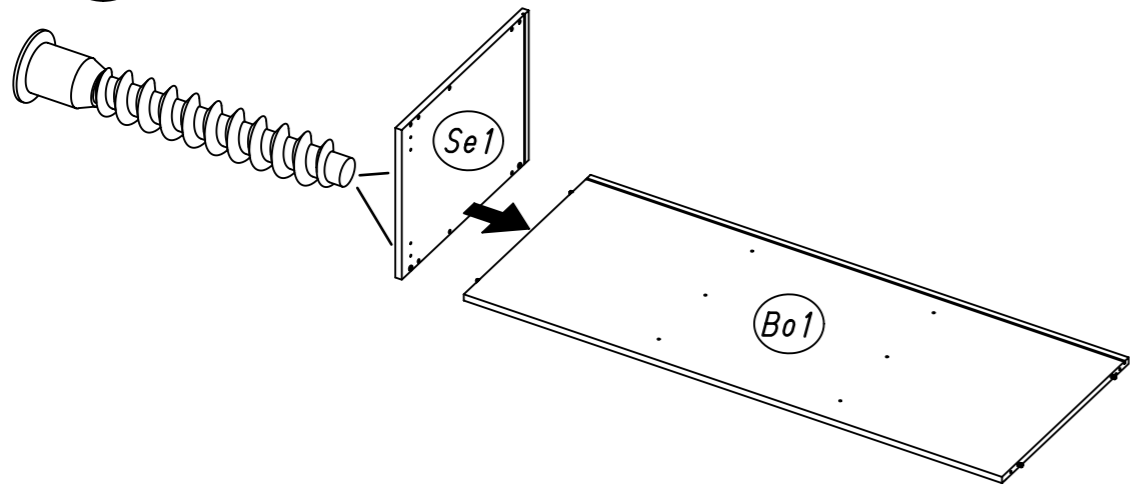

4 807 Typ III 807 Typ IV

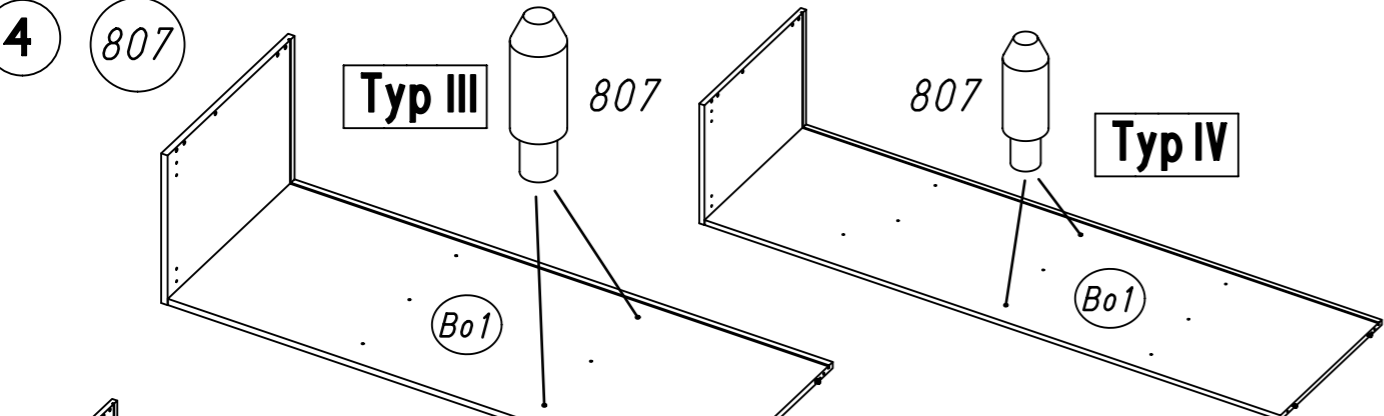

807 Typ V

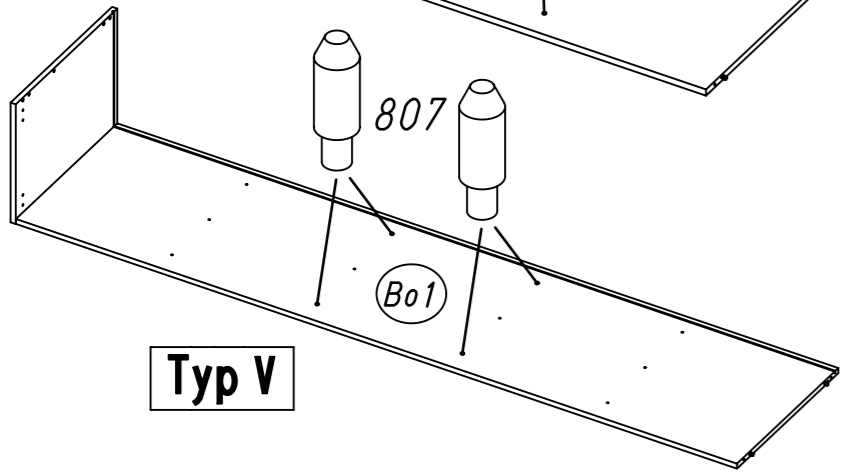

5 Typ III Ms Ms Typ V Ms Ms Bo1

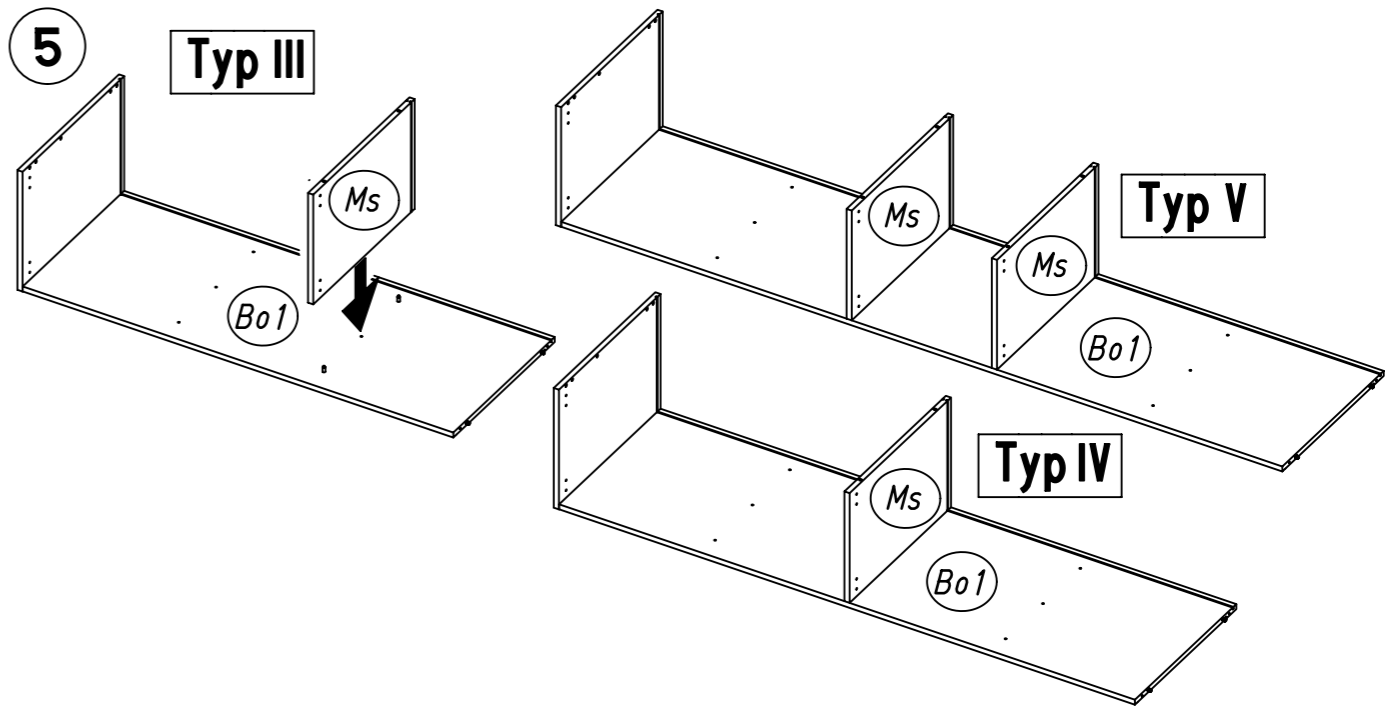

6 Typ I Typ II Typ III Typ IV Typ V

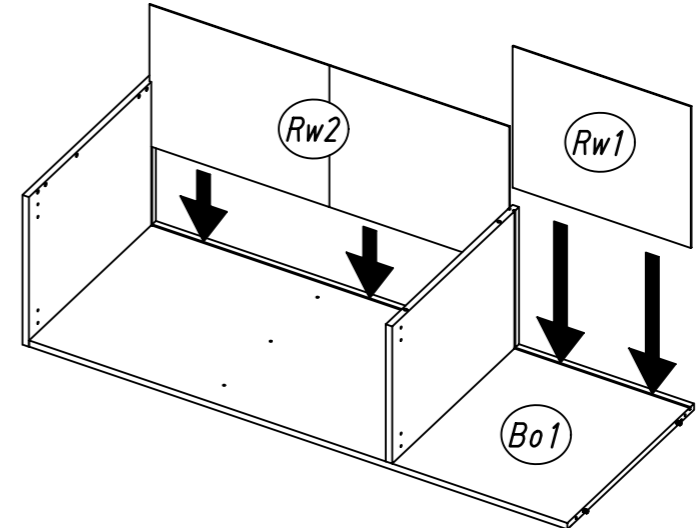

7 807 Typ V 807 807 Typ IV

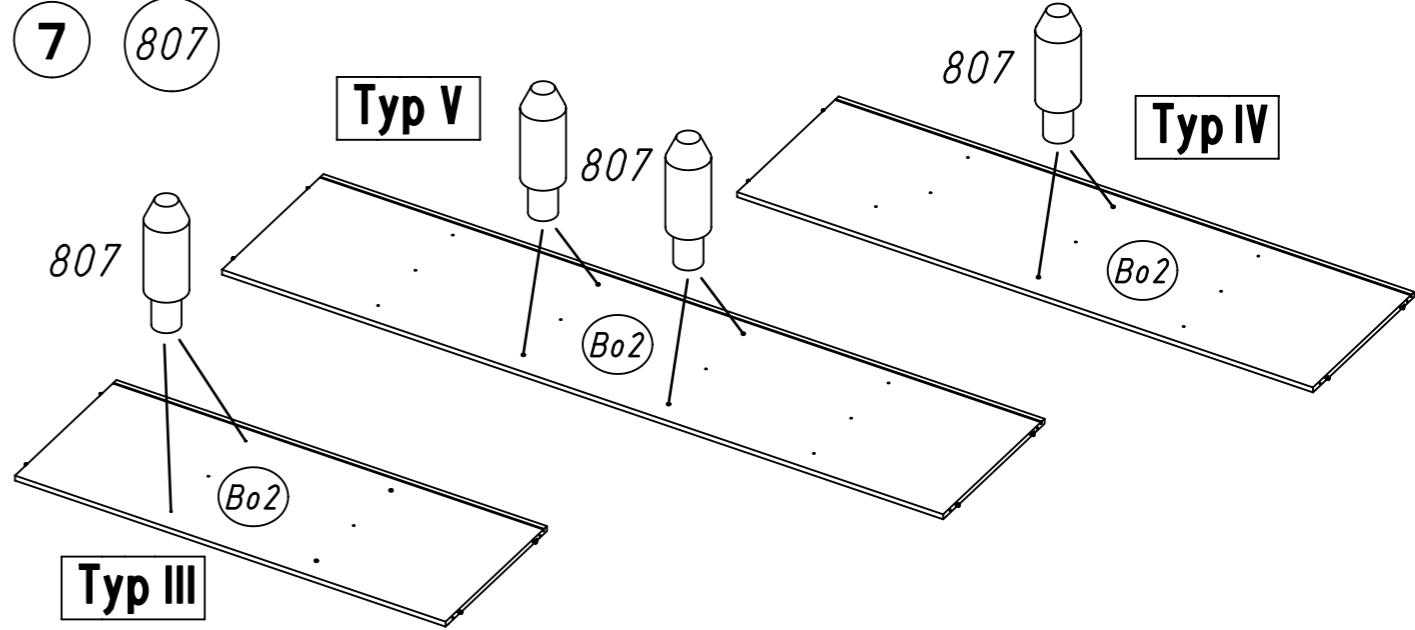

8 233 Typ I Typ II Typ III Typ IV Typ V

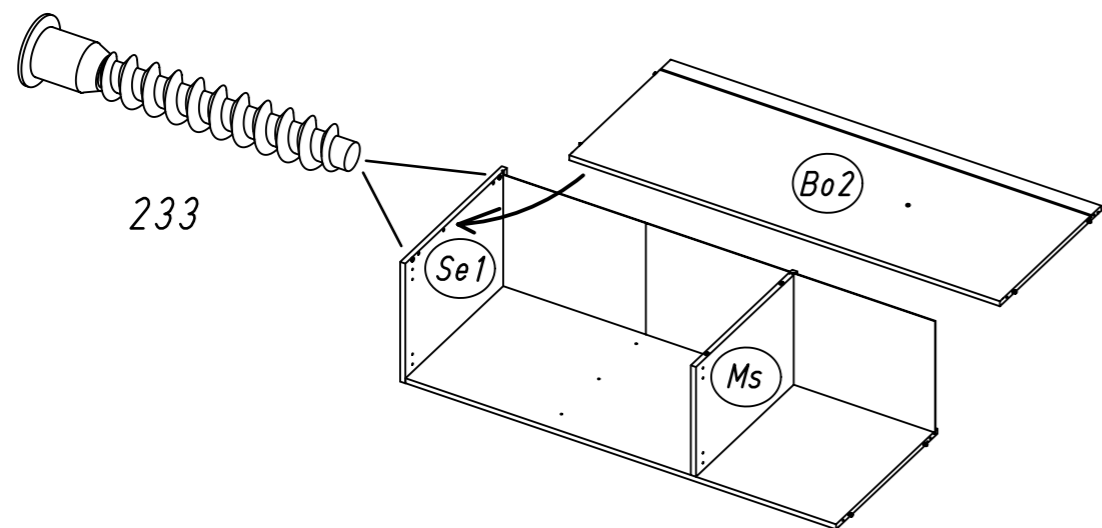

9 233 Typ I Typ II Typ III Typ IV Typ V

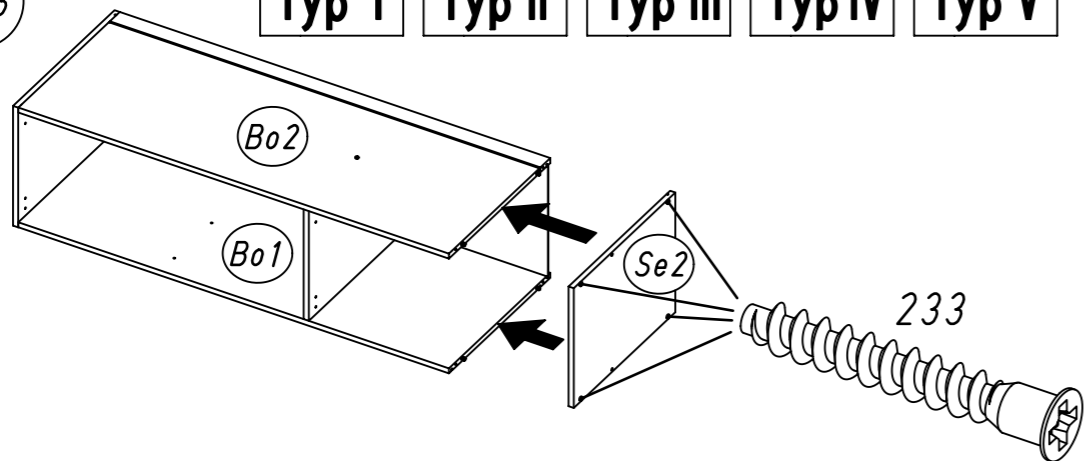

10 225 Typ III Typ IV Typ V

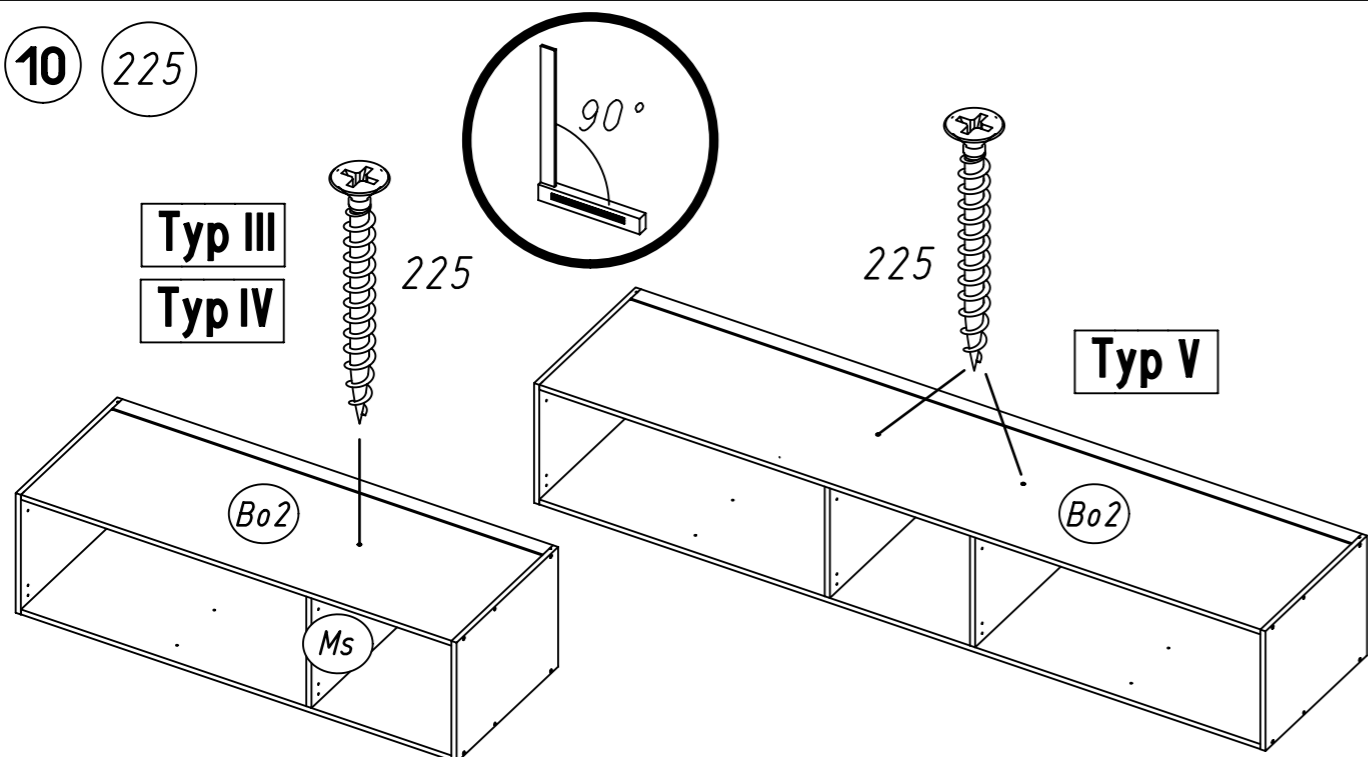

11 225 Typ V

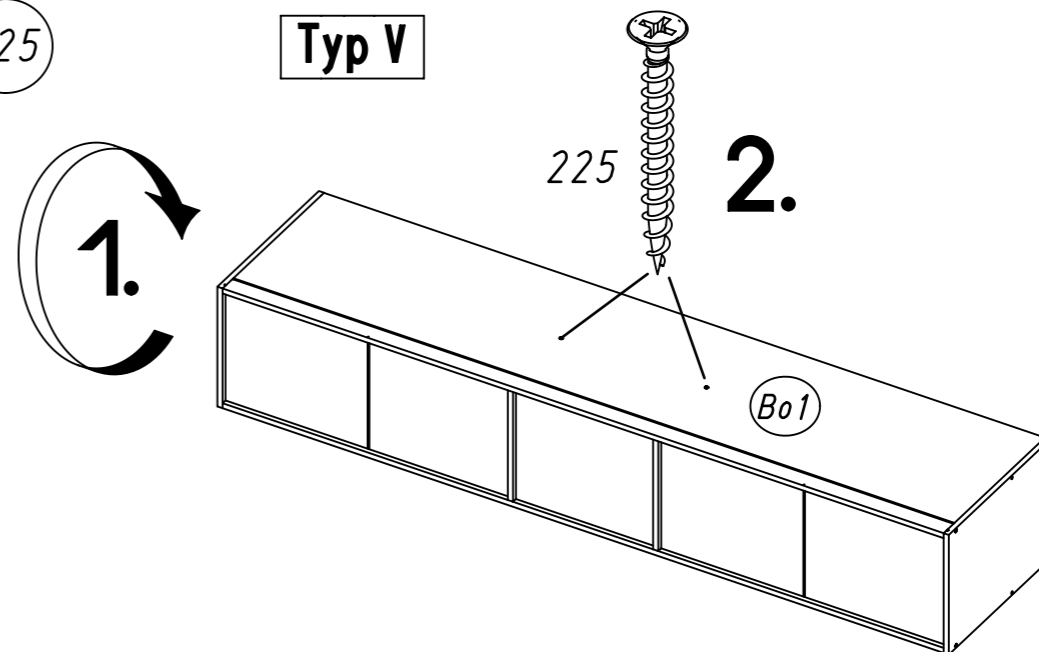

12 213 Typ I Typ II Typ III Typ IV Typ V

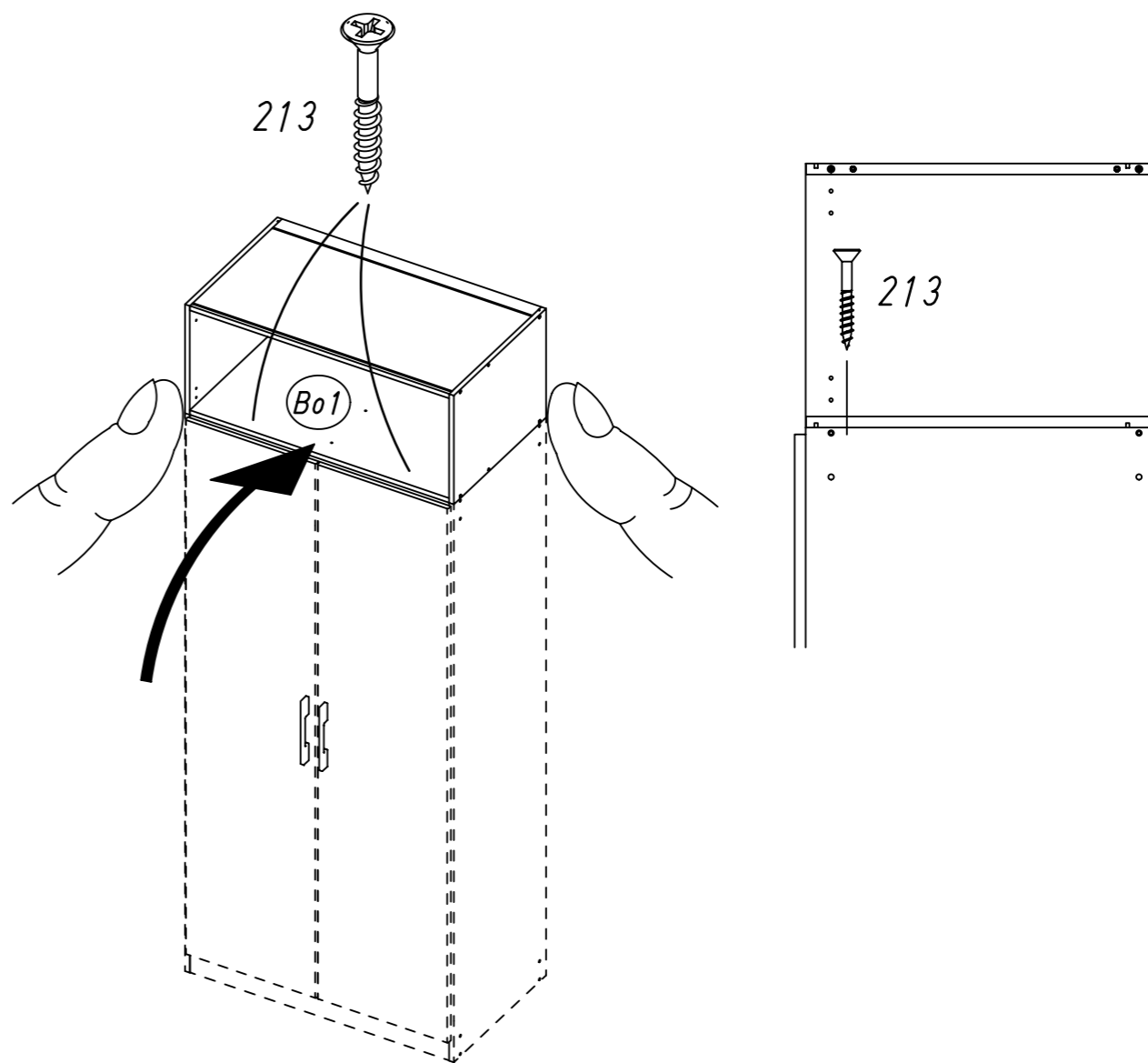

13 116

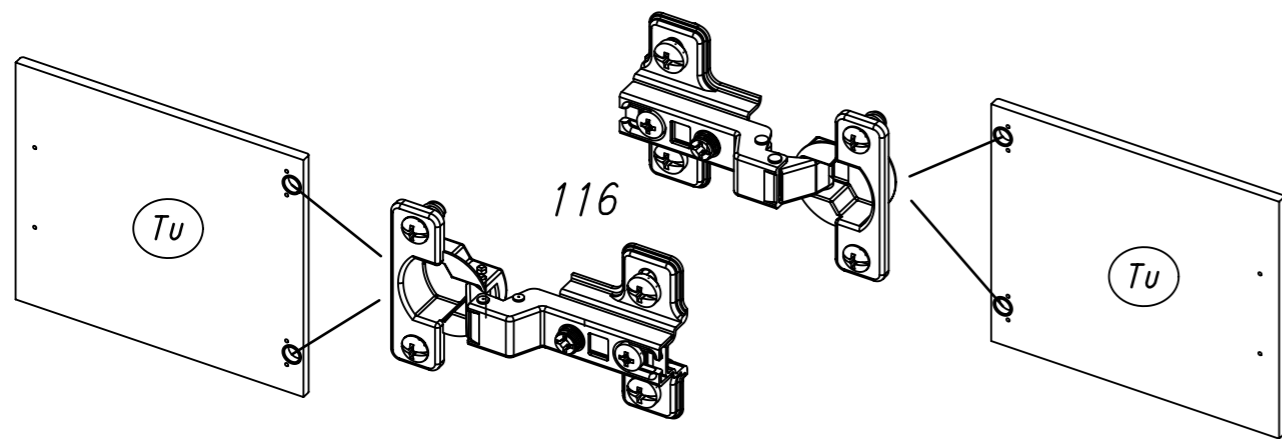
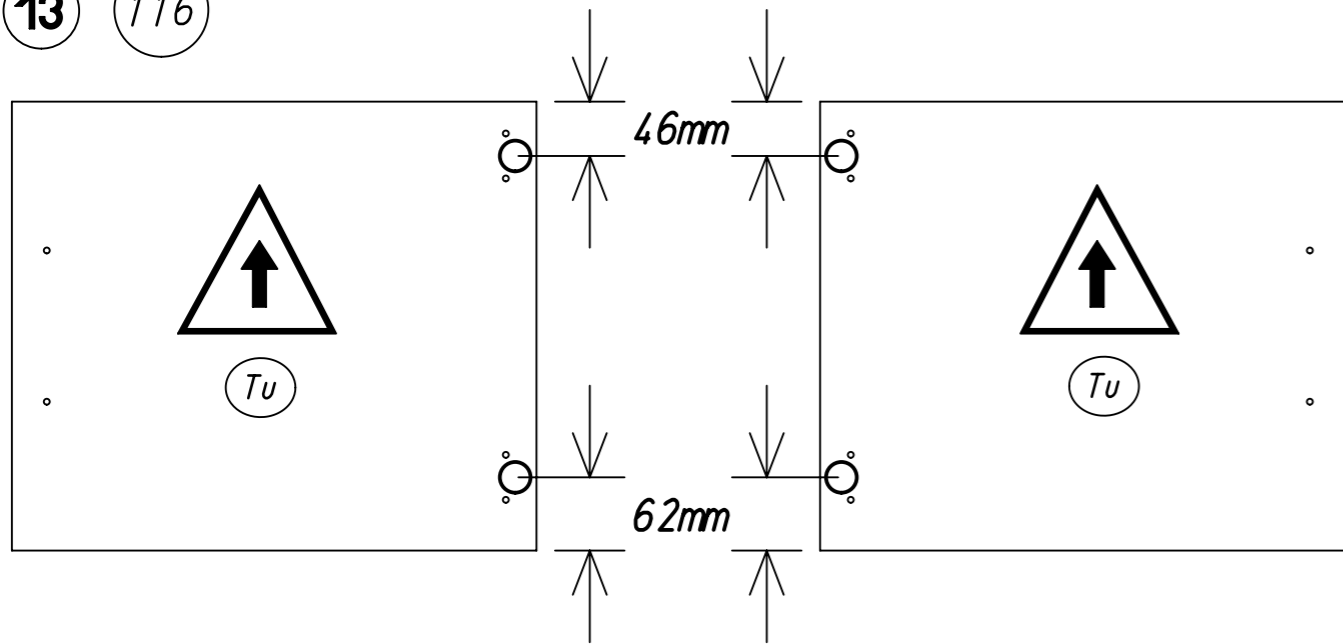

Typ I Typ II Typ III Typ IV Typ V

14

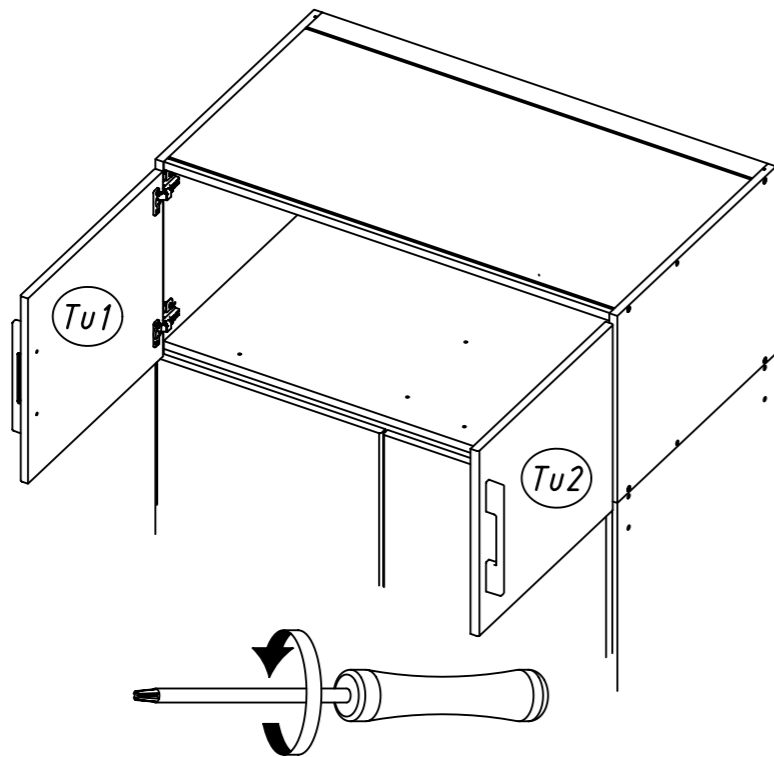
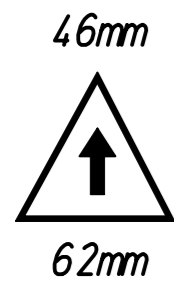

15

ABD-FOLIE

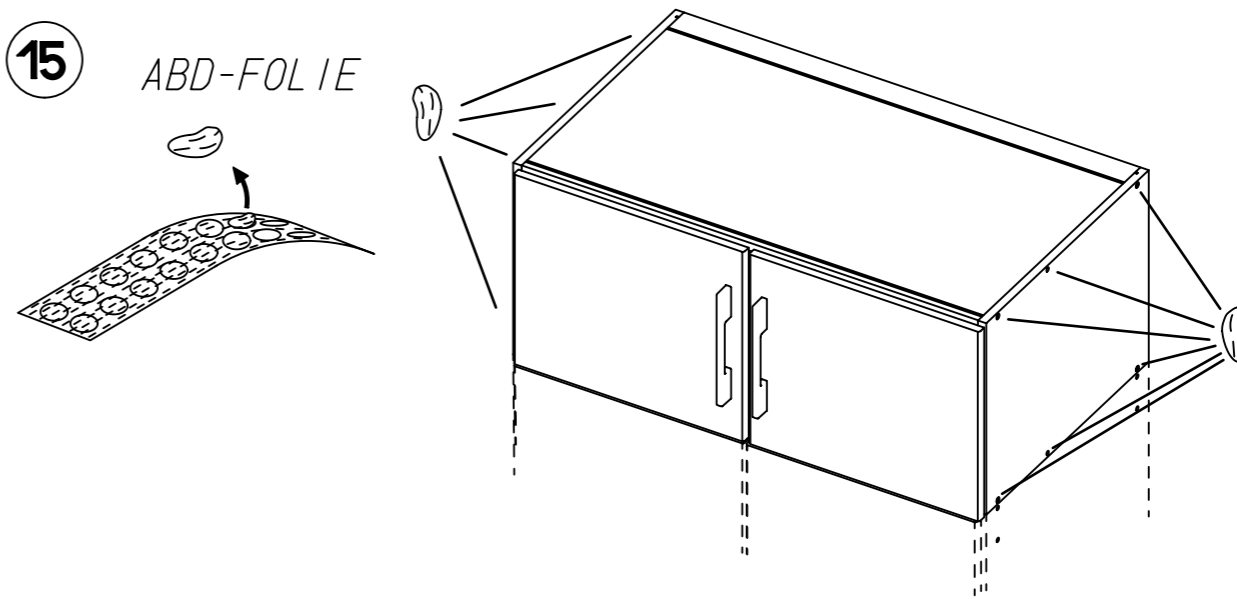

16

