

1	x1	ca. 1195x535x15	1/2
2	x1	ca. 1195x535x15	1/2
3	x1	ca. 1917x504x15	1/2
4	x1	ca. 1917x504x15	1/2
5	x1	ca. 1917x504x15	1/2
6	x2	ca. 1909x395x15	2/2

7	x1	ca. 1629x395x15	2/2
8	x1	ca. 490x292x15	1/2
9	x1	ca. 489x383x15	1/2
10	x3	ca. 390x375x15	2/2
11	x2	ca. 278x80x12	2/2
12	x2	ca. 350x80x12	2/2

13	x2	ca. 278x80x12	2/2
14	x2	ca. 360x276x2,5	2/2
15	x2	ca. 395x137x15	2/2
16	x1	ca. 1926x782x2,5	2/2
17	x1	ca. 1926x385x2,5	2/2
18	x1	ca. 773x390x15	2/2

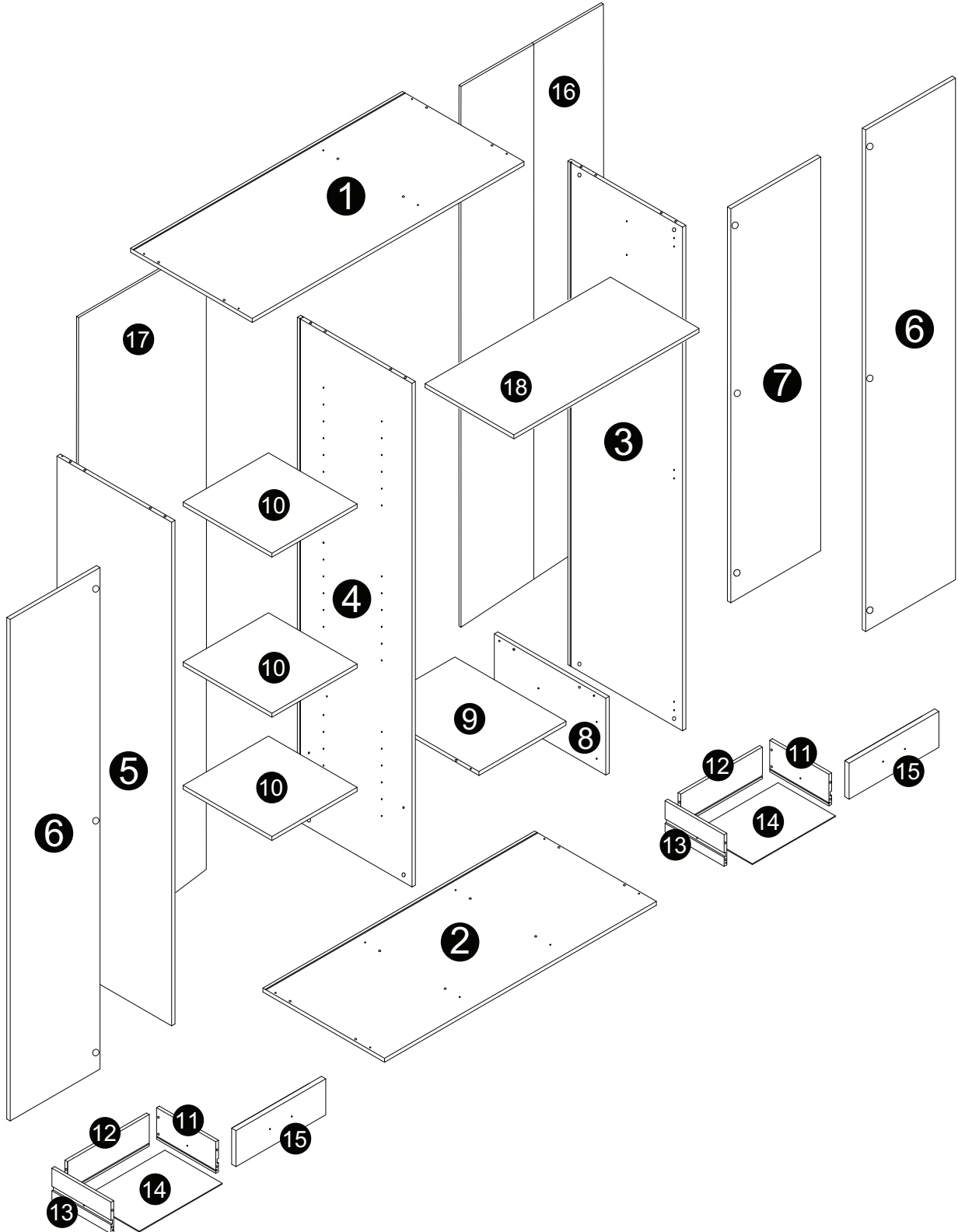

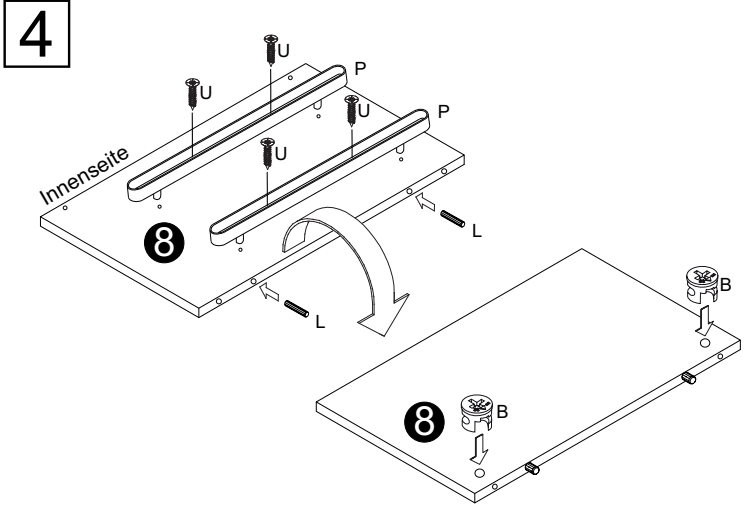
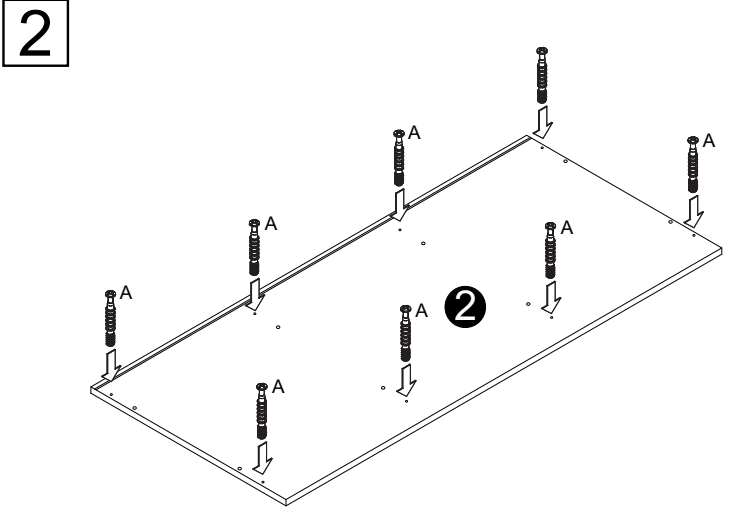
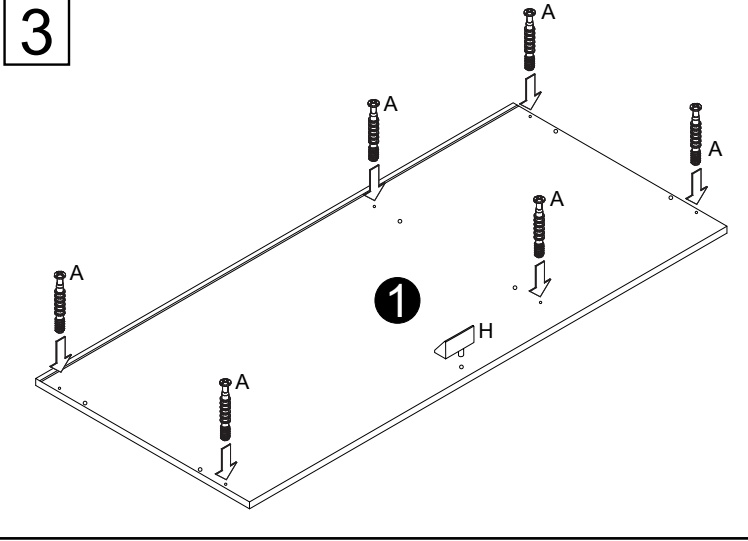
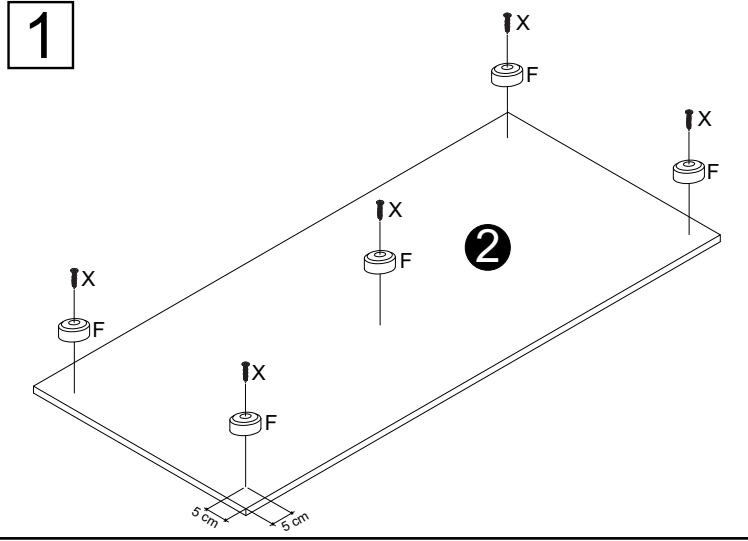
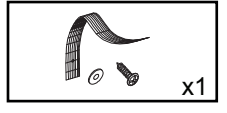
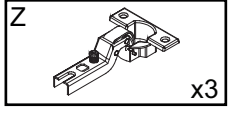
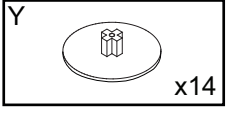
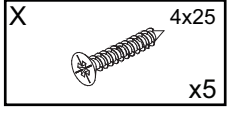
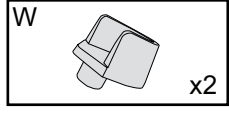
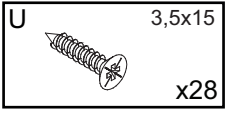
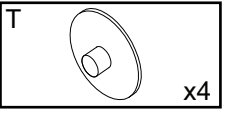
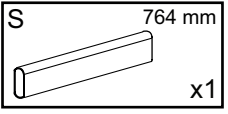
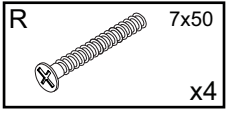
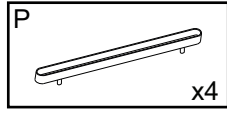
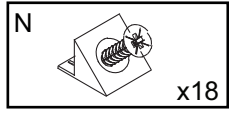
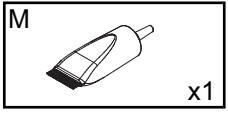
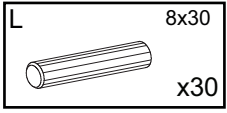
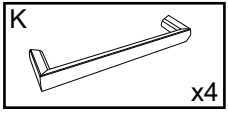
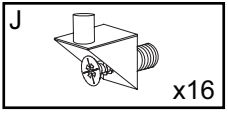
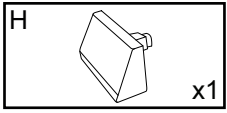
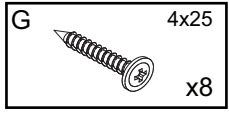
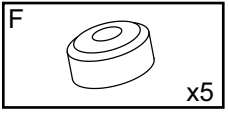
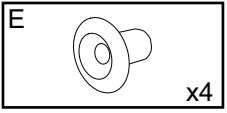
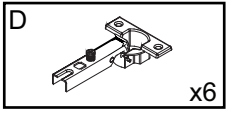
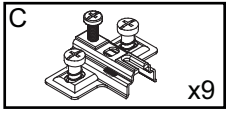
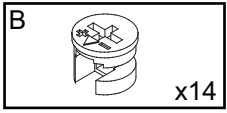
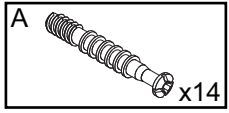

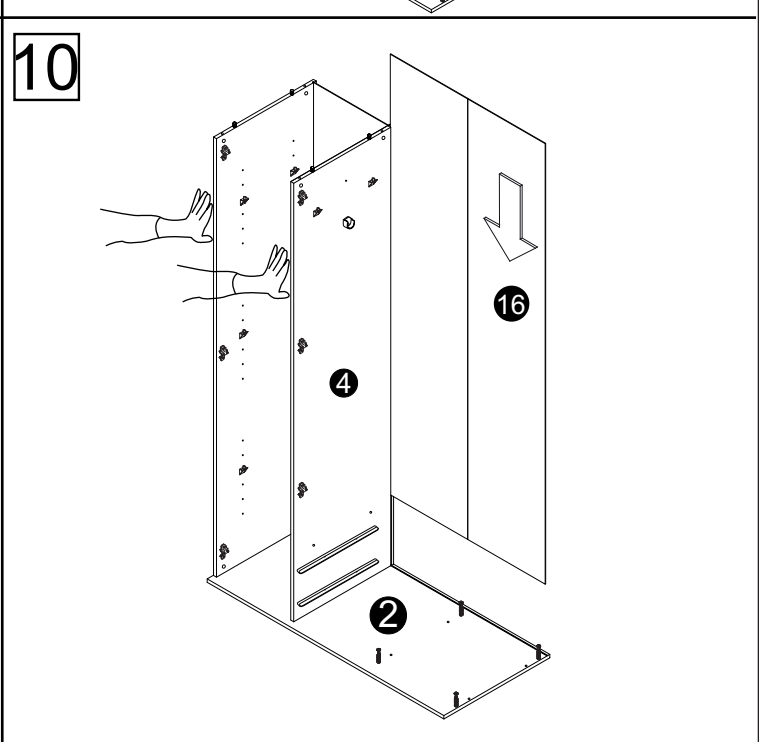
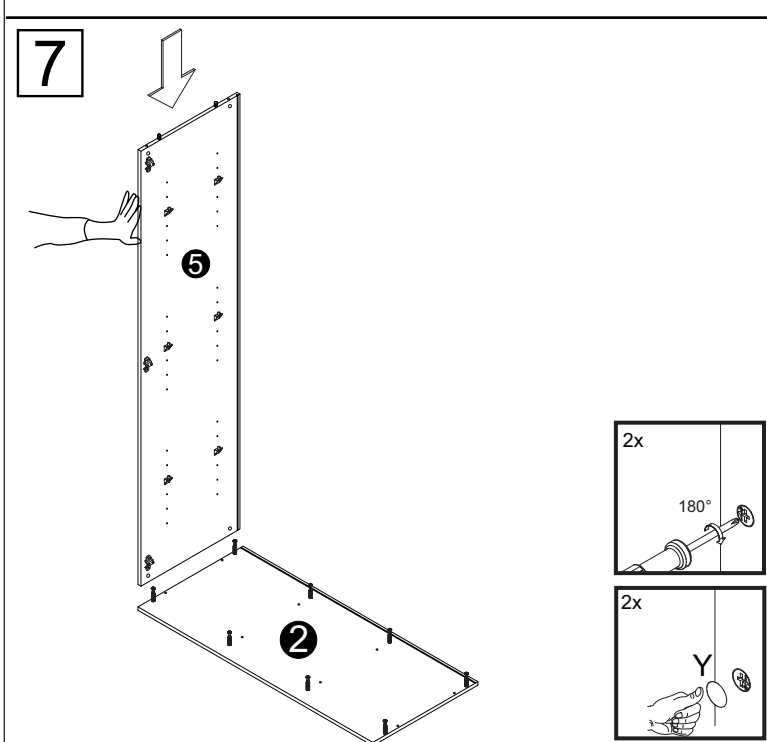
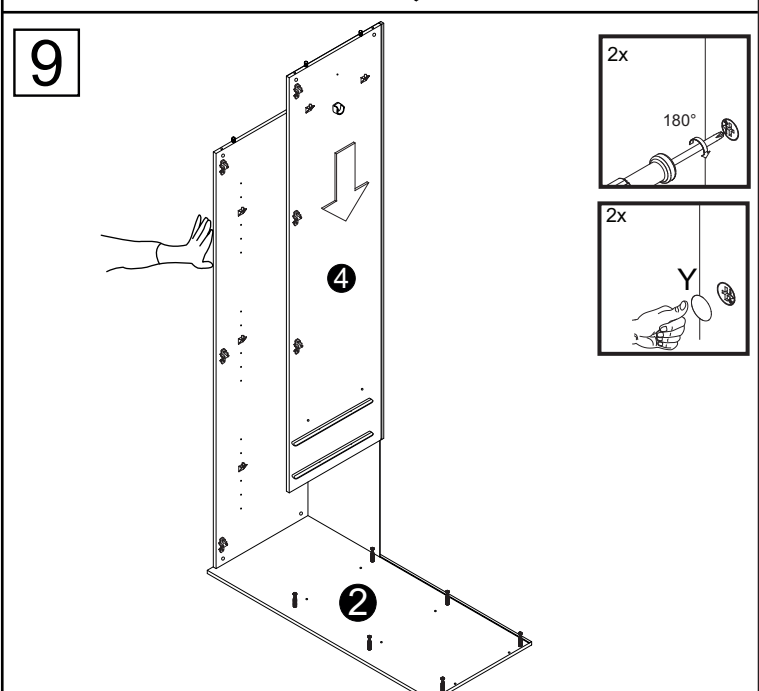
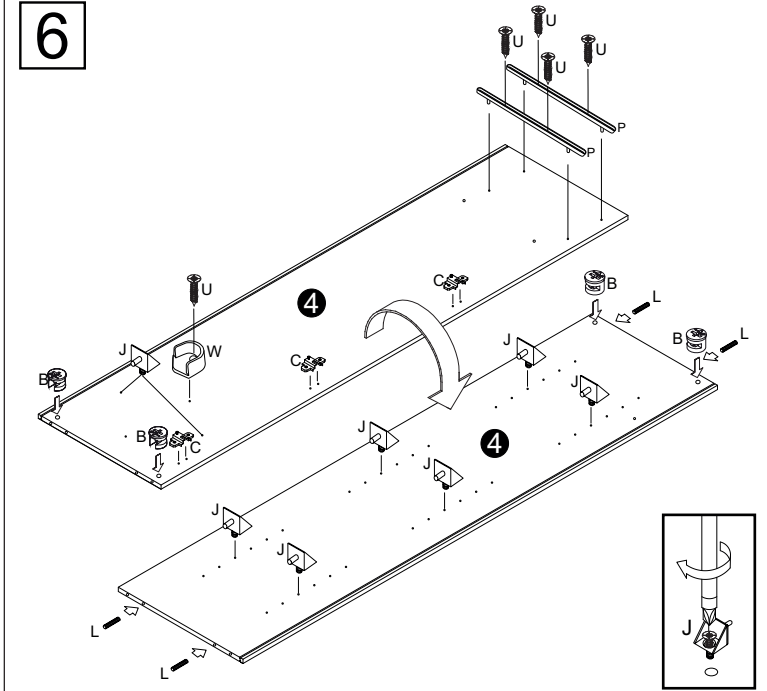
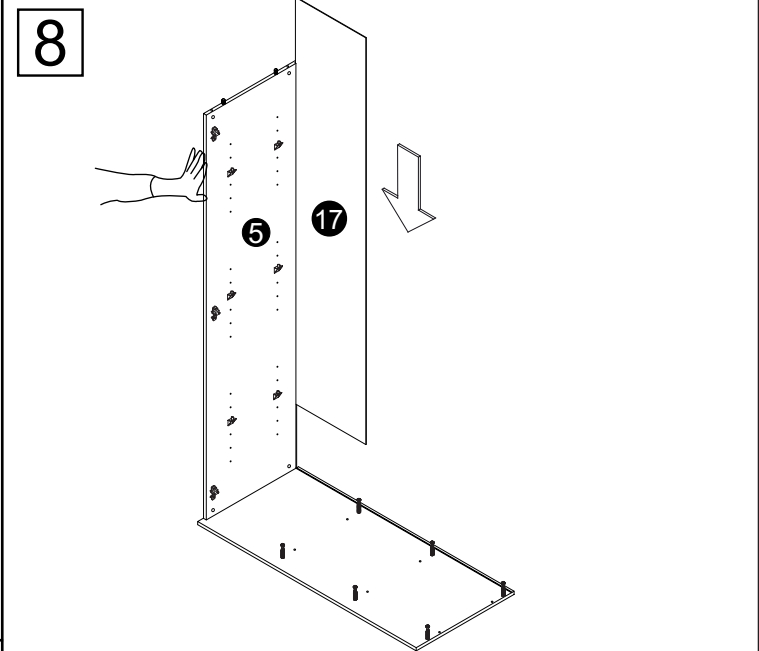
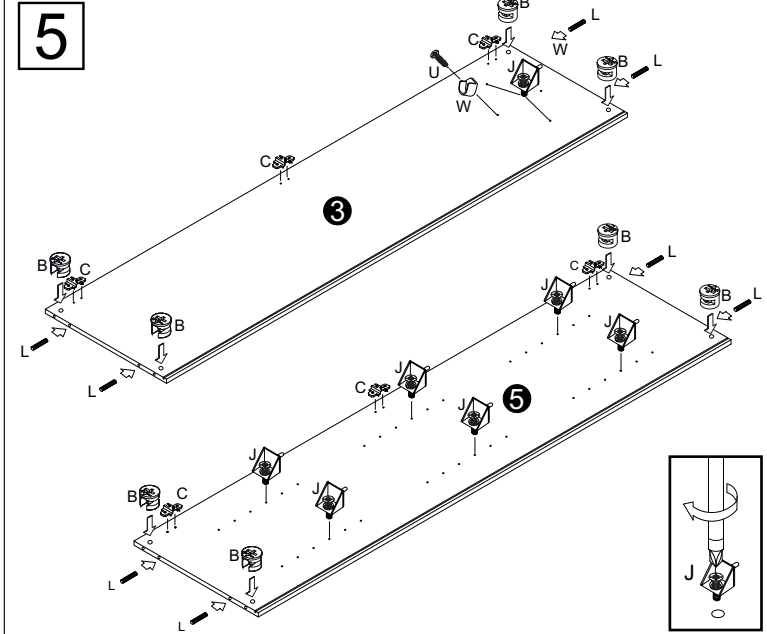

11

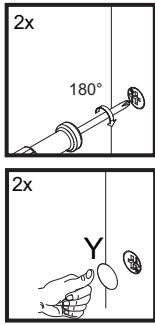
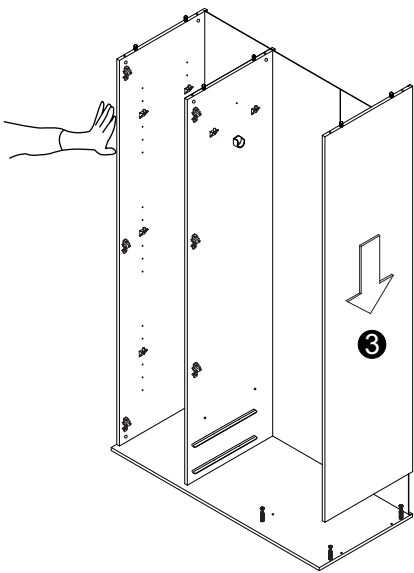

14

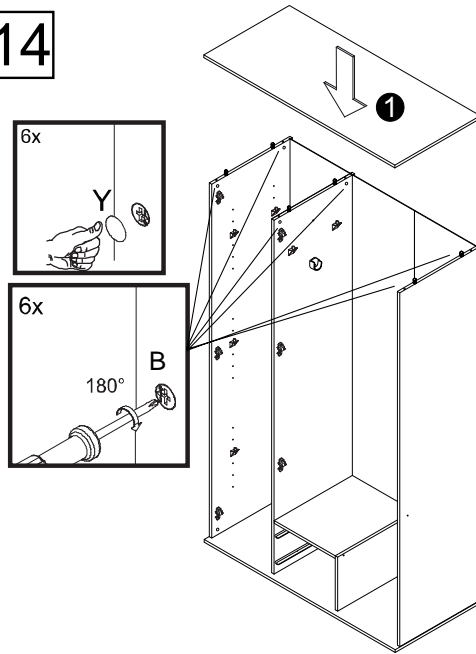

12

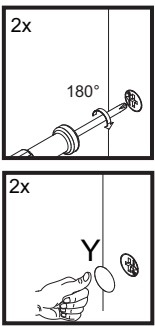
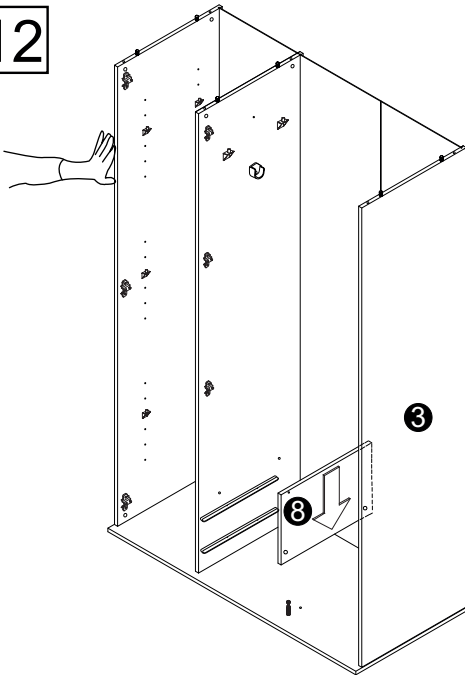

15

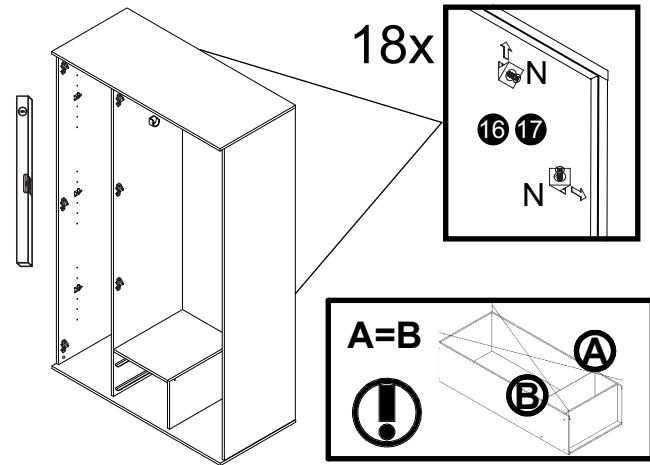

13

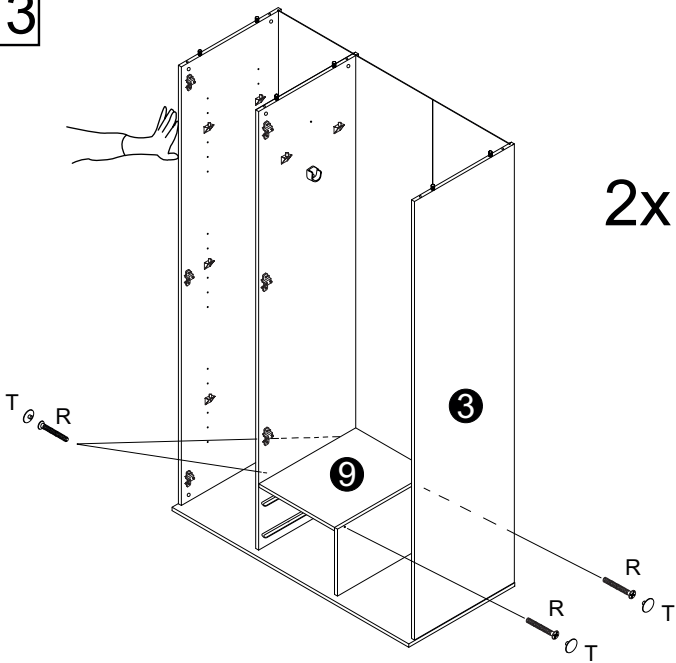

16

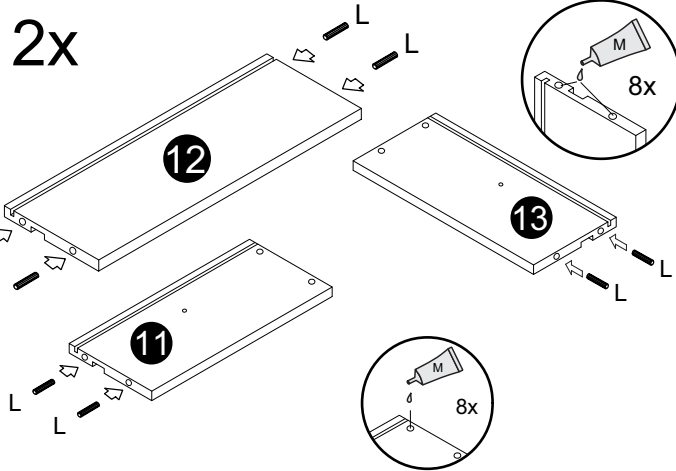

17

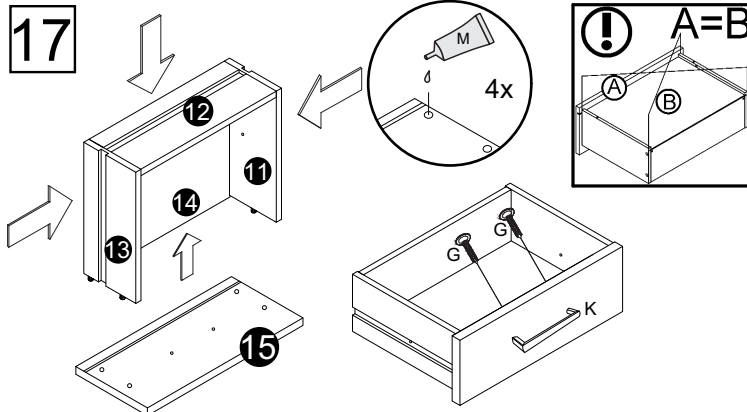

18

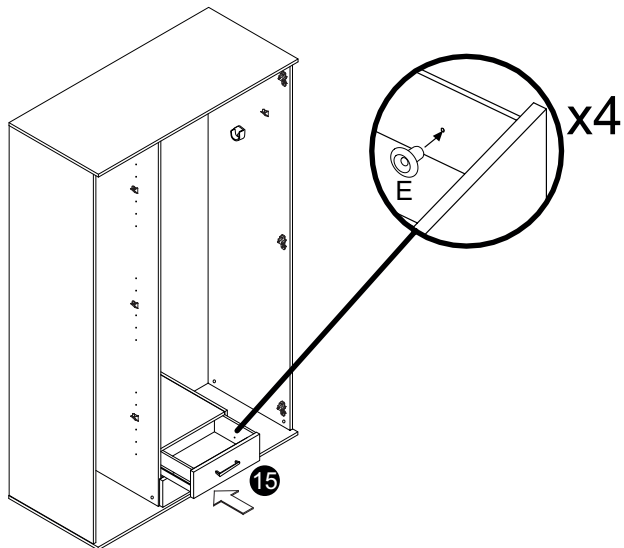

20

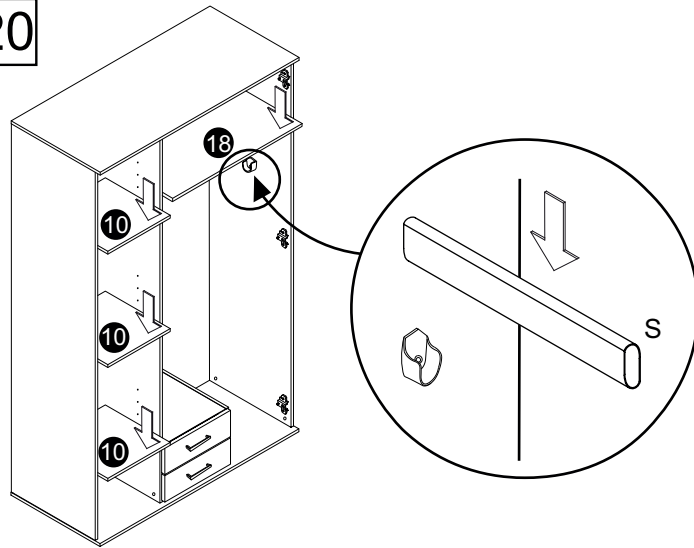

19

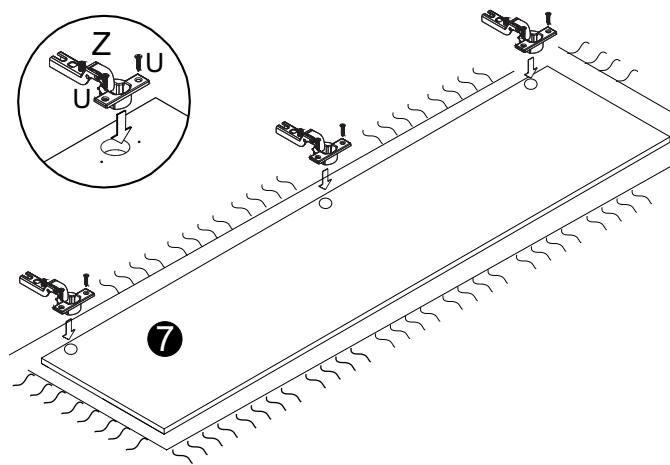

21

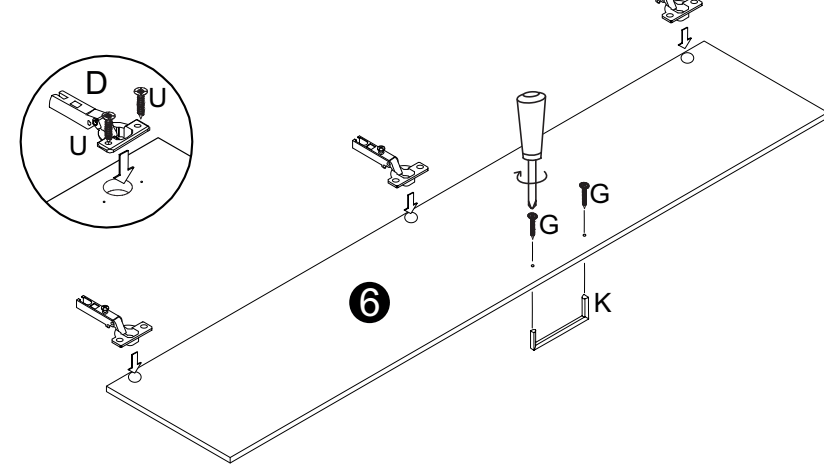

22

